



défier les limites
avec
AERO A



+33 5 54 54 40 74
www.facade-textile.com



L'Aero A est le profilé qui a permis de réaliser l'iconique façade textile du campus Airbus à Toulouse.

L'exigence de cette opération nous a permis d'innover sur le design du profil en créant des formes aérodynamiques ayant une fonction auto-nettoyante.

La forme Aero est inspirée des lignes de l' A 380 qui lui donnent ce style fluide, aérien et dénué de surfaces planes.

UNE FAÇADE TEXTILE VENTILÉE EFFICACE ET FLEXIBLE

◆ Thermique :

Associée à la membrane Frontside View 381 la façade textile bloque jusqu'à 78% de la chaleur solaire.

◆ Résistance :

Avec un test en laboratoire justifiant une rupture à 4,2 T ml, la solution Aero devient un des systèmes les plus résistants du marché.

Son efficacité a été prouvée lors du passage de l'ouragan Irma en Floride en 2017.

◆ Inertie :

Son design permet de réaliser des tensions jusqu'à 2 m sans renforts.

UN SYSTÈME CONSTRUCTIF SIMPLE

◆ Technique :

Avec seulement 8 éléments incluant la toile vous pouvez réaliser l'ensemble des formes que vous souhaitez.

Le principe de tension FTI ne nécessite pas de confection pour tendre les toiles.

Du rouleau au cadre, il n'y a qu'une étape.

L'aero A est doté d'un canal technique qui accueille un écrou carré M12, ce point de fixation coulissant permet de nombreuses possibilités d'accroche

◆ Outillage :

Maillet anti rebond + Rouleuse FTI + outillage de base.

UNE FAÇADE TEXTILE DESIGN ET ESTHÉTIQUE

◆ Légèreté des lignes :

Avec une toile retournée sur l'arrière du profilé, la structure disparaît du champ visuel extérieur.

Son design sans surfaces planes ne permet aucune stagnation des particules végétales, ainsi la toile ne marque pas les encadrements.

Son design spécialement étudié pour la façade Airbus permet d'offrir avec le même profilé un joint creux visuellement identique avec des angles de +/-40 degrés.

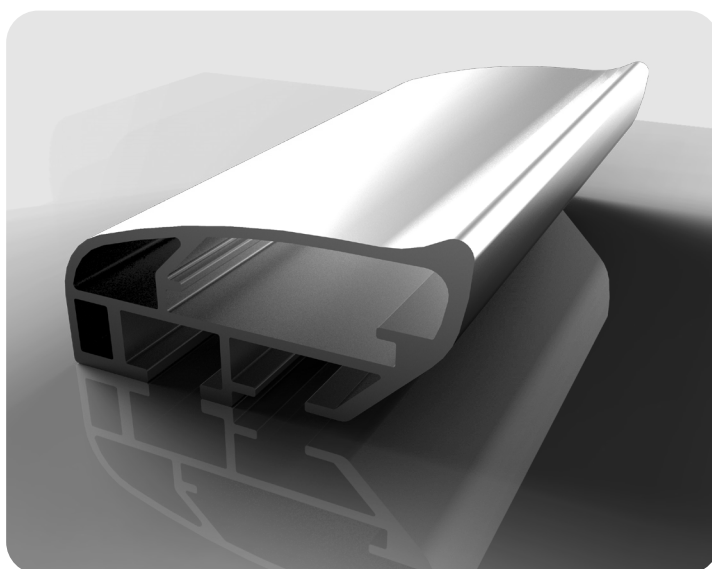

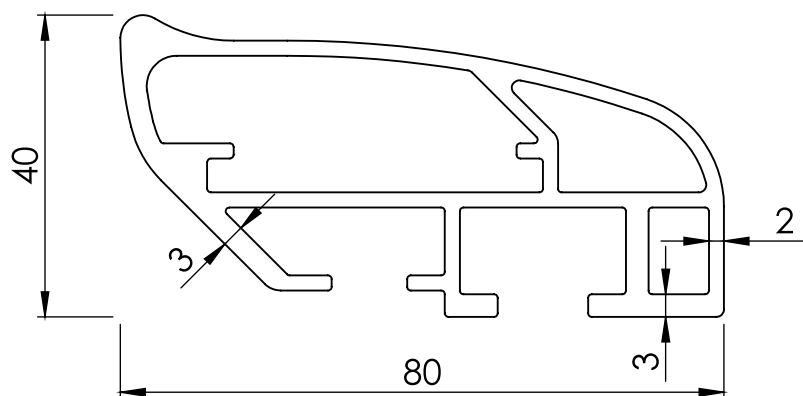

Echelle 1:1

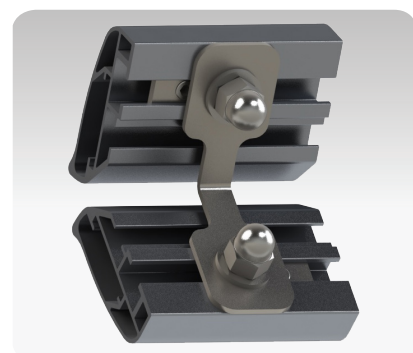
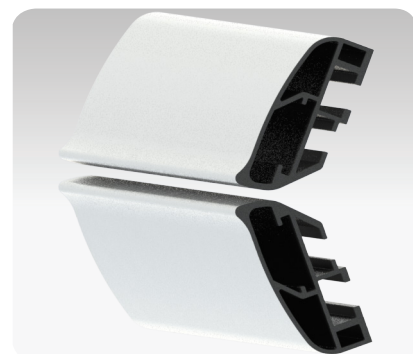
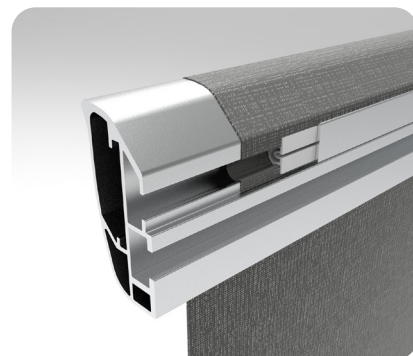
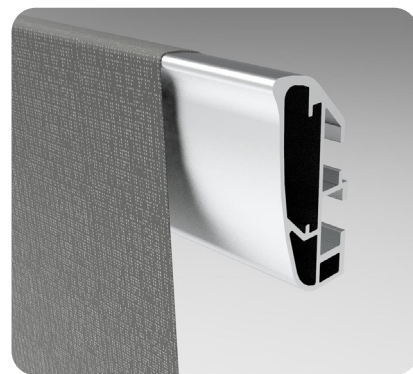

CARACTERISTIQUES

Largeur	80 mm
Epaisseur	40 mm
Poids	1,9 Kg / ml
Surface maxi conseillée	4 m ²
Inertie	Lxx = 91764.50 Lxy = 83315.61 Lxz = 0.00 Lyx = 83315.61 Lyy = 460610.82 Lyz = 0.00 Lzx = 0.00 Lzy = 0.00 Lzz = 552375.32
Traitements de surfaces	Anodisé 15μ / Brut / Thermolaqué
Longeurs	2650 mm ou 5300 mm
Vendu avec	Gripp PVC + kit de cales + Key



RESISTANCE AU VENT
250 Km/h



RECYCLAGE 100%



RUPTURE 4,2T/lm



SURFACE 4 m²/cadre



FORMES 3D



SYSTÈME BREVETÉ

Accessoires aéro A

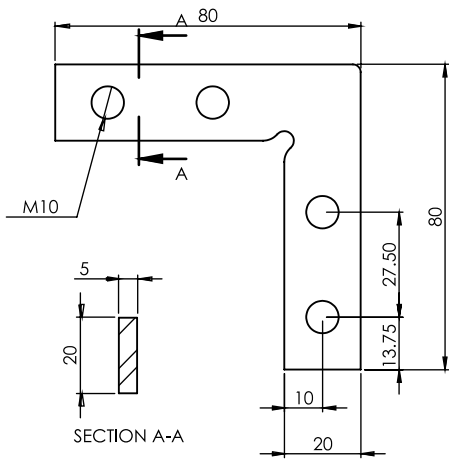

AERO A - EQ90T

Echelle 1:2

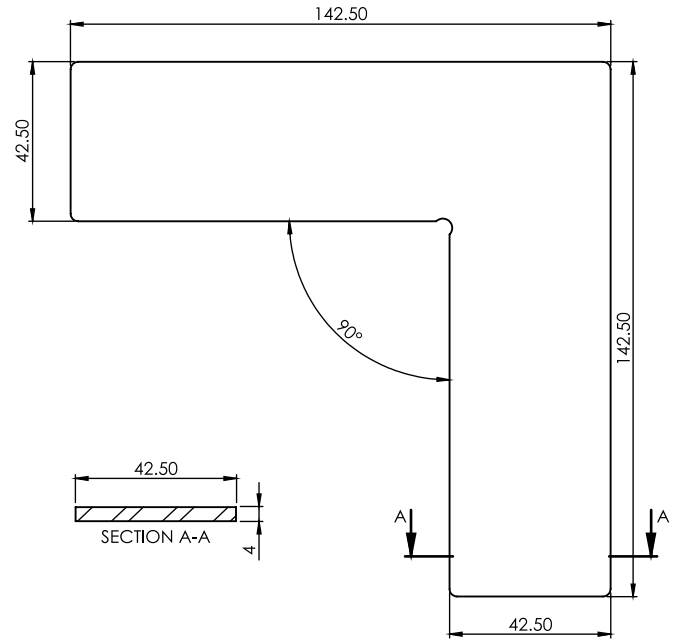

AERO A - EQ90

Echelle 1:2

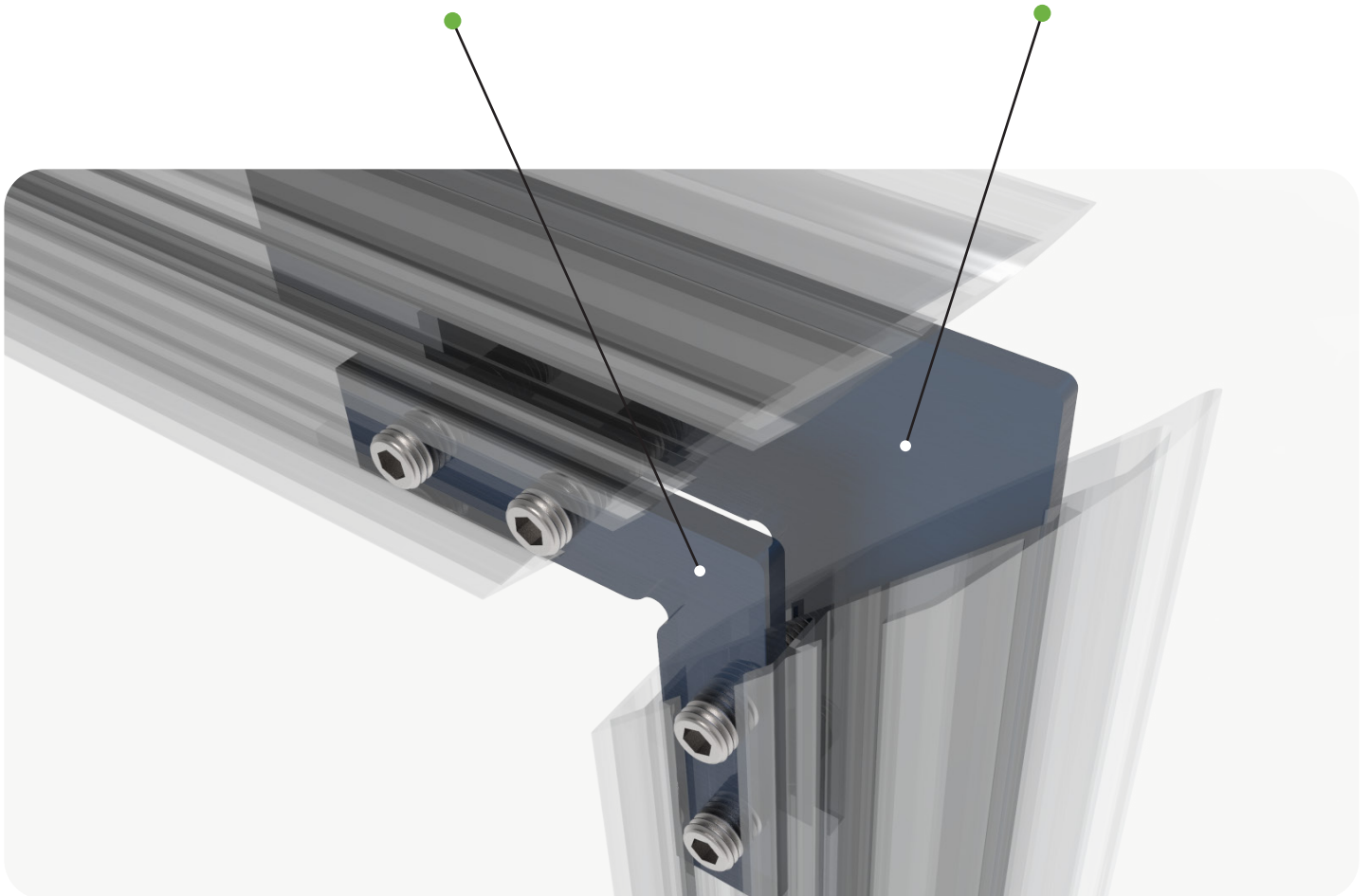

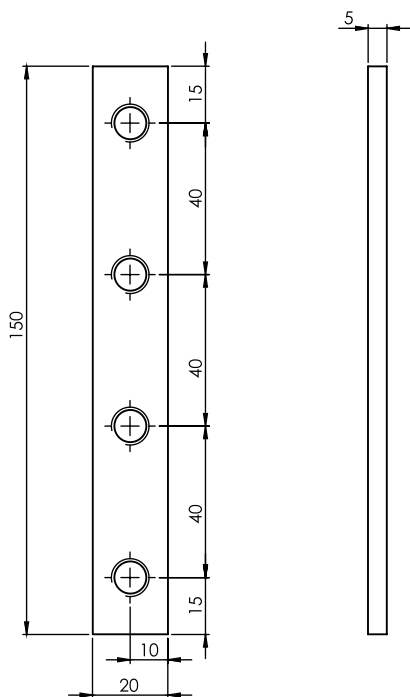

AERO A - Méplat de jonction R4T

Echelle 1:2

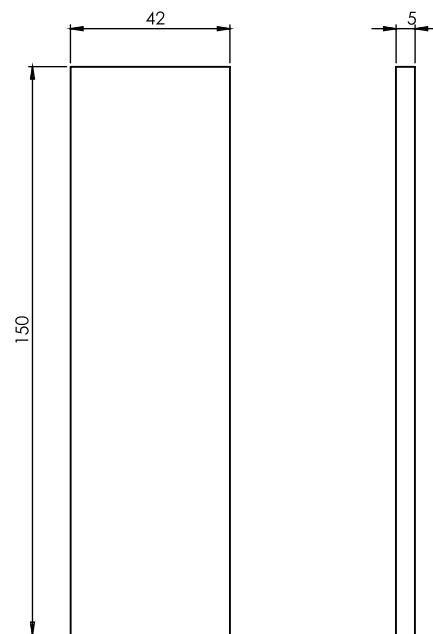

AERO A - Méplat de jonction

Echelle 1:2

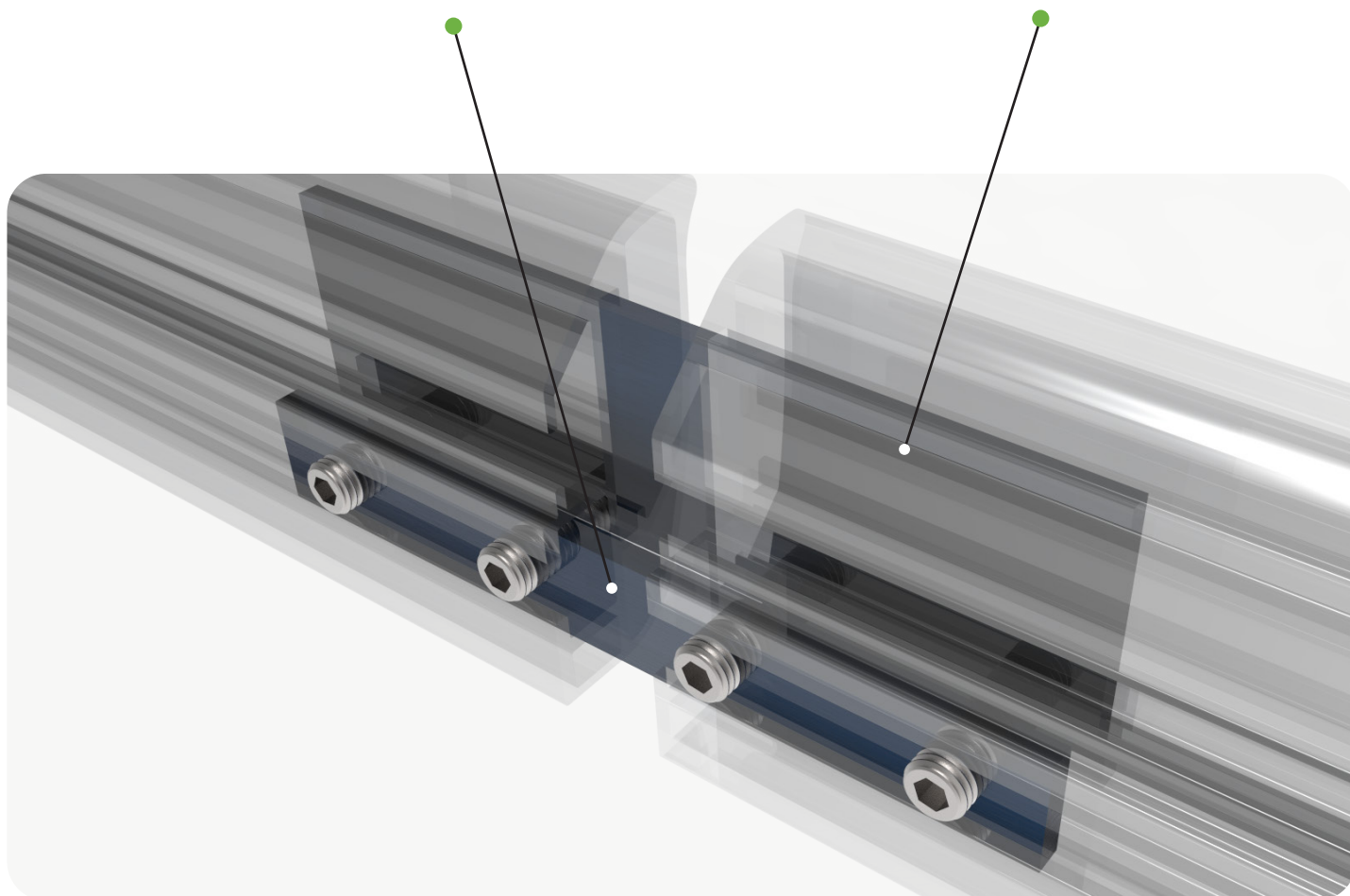

The requirements of the Airbus project

The Airbus architect requirements streamlined the characteristics of a true lightweight architecture solution, focusing on the following aspects :

- Elimination of heavy structures such as square, U or H sections in the visual area.
- The supporting structure consists only of steel plates to allow wind resistance from the front while leaving only 10 mm of structure visible to the occupant (1, 2, 3).
- The canvas had to wrap around the profile to minimize its presence in the space (4).
- A 10 mm trickle of light had to pass between the diamond facets (5). This space allows the occupant not to feel the heaviness of the metal structure and to feel in a controlled way the well-being of the sun's rays (6).

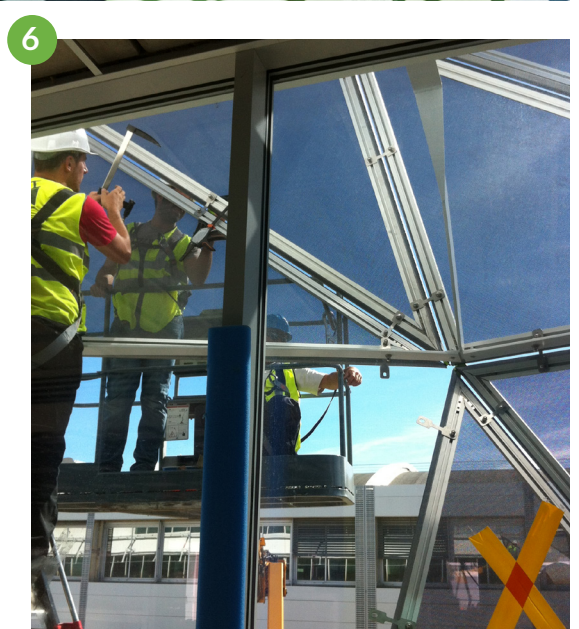
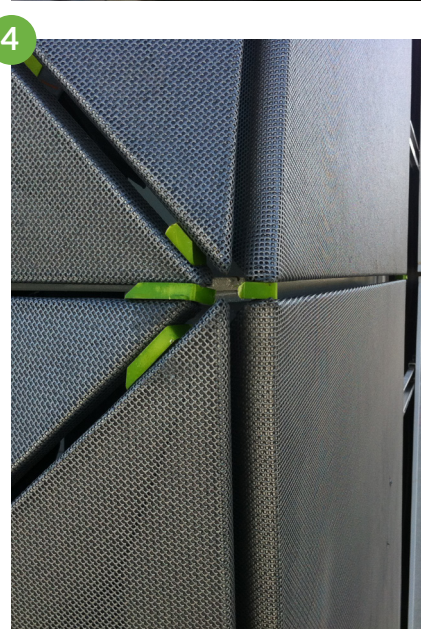
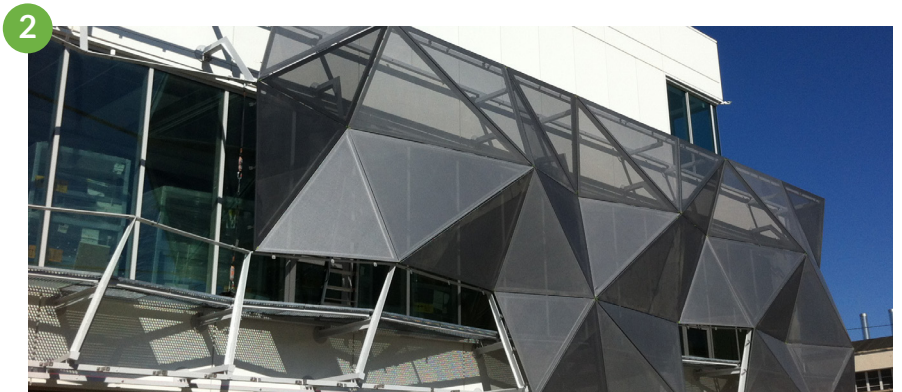
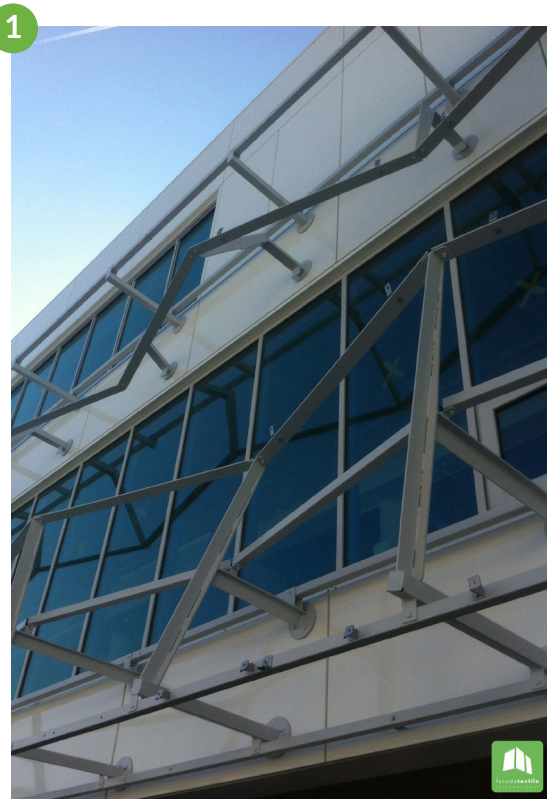

The requirements of the Airbus project

The entire structure also had to comply with mechanical standards in aeronautical space (Aluminium/Steel corrosion management by insulation, no self-drilling fasteners, ability to withstand vibrations and kerosene fallout). (07)

In order to optimize the light between the frames, the stainless steel connecting brackets are cut in the shape of an 8 and fixed with a cap nut. (08, 09)

The shape of the Aero A profile has been designed to allow a 10 mm shadow gap with angles of $\pm 40^\circ$ in and out (10)

To date, the balance between technology and aesthetics designed by the team of the architect CALVO - TRAN VAN has given full satisfaction to the thousands of users who have lunch in this relaxation area. (11, 12)

